



CONCRETE DISTRIBUTORS
with
HYDRAULIC BOOM

- B**
Series
B 308
B 212
B 312
B 15
B 17
B 18
B 21



User Friendly



Remote Control

Ultra Light design hydraulic placing booms are made of High Strength Steel which provides long life, light weight and practical use. Distribution area / weight-feet clearance rates are unbeatable. Optimization in the design is to maximize the practicability. Therefore the users describe the equipment as "job-site friendly equipment".

Heavy-Duty Slew Gear

All Atabey B-Series concrete placers has heavy-duty slew gears integral with reducer gear-box. The system is much more reliable as compared to generally used worm-gear reducers. Although worm gear reducers are sufficiently strong against pre-determined loads, they are weak against small accidental hits of the boom end. (that can somehow happen in construction job-sites)



Modular Construction With Detachable Boom Unit

Single-pin split-frame system; easy to handle and transport; user-friendly solution for tower crane capacity limitations.



B Series / General Features



Emergency Hand Pump

Emergency hand pumps are standard on all Atabey B-Series placing booms never stop concrete pouring; even in case of power cut, concrete placing can be finished by manual hand pump. No "cold-joints" with Atabey placers.

Infinite Rotation System With Slip-Ring Mechanism

There is no any limit of turning during operation. One of the considerations during positioning of conventional spider booms is to plan starting angle position in convenience with pouring steps. Even if the spider boom has 360° total slew turnability, that is not perfect. People frequently try to push further with end-hose at the slew turn limits in order not to wait for a complete reverse turn. With Atabey, there is no such a limit: easy, friendly operation.



Ballast Boxes

Easy start up with Atabey placing booms. Readymade ballast forms supplied with the equipment. No need to construct formwork etc. to obtain ballast weights. It is as easy task as filling the boxes with concrete only!



Model Names With Respect to "Horizontal Reach" Values

2 Element Model

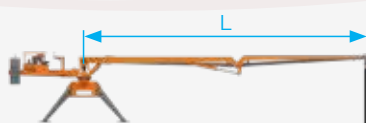

Model	L
B 212	12 m

3 Element Models



Model	L
B 308	8 m
B 312	12 m
B 15	15 m
B 17	17 m
B 18	18 m
B 21	21 m

B Series / 4-Wheel Carriage Options

- With or without traction
- Hydraulic outriggers
- Remote control for self-travel & steering



K₁ - B 308, Striker

K₂ - B 212, B 312

K₃ - B 15, B 17, B 18

K₄ - B21



B Series / 4-Wheel Carriage Options

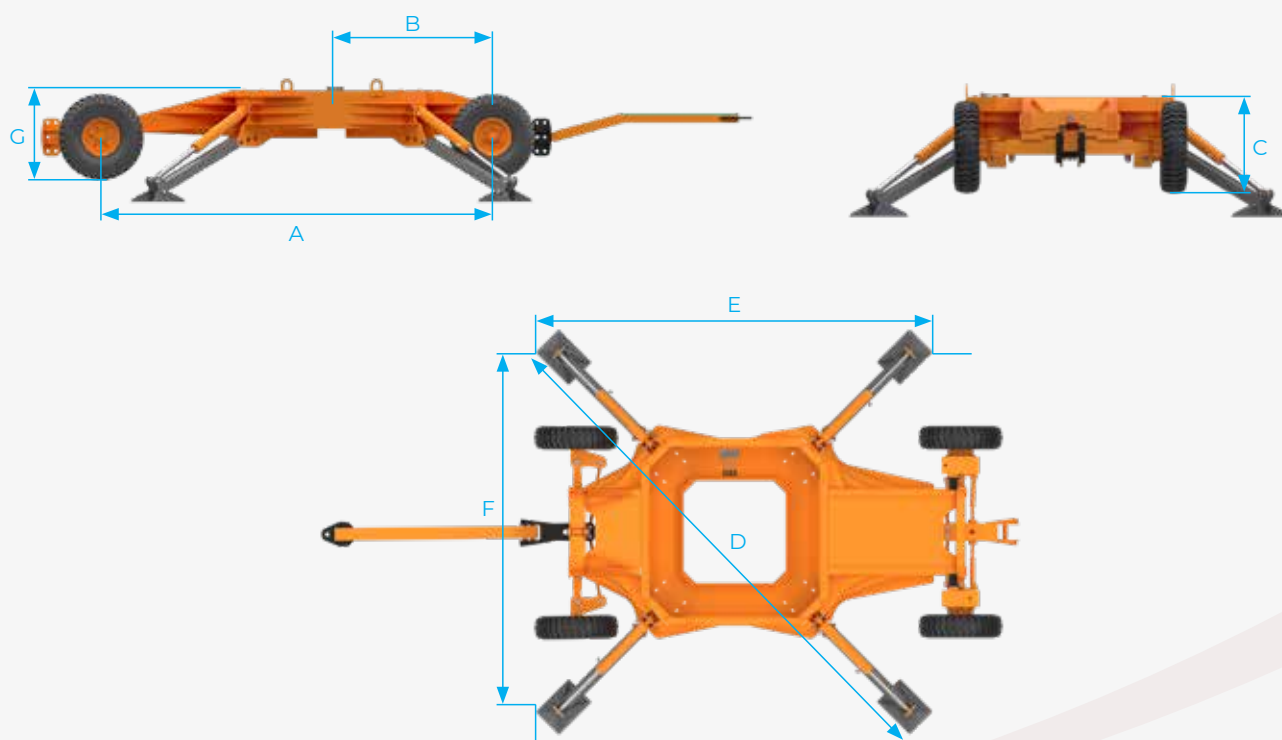

Models	A	B	C	D	E	F	G	K	KW ₂	KW ₄
K ₁	3820 mm	2297 mm	828 mm	5030 mm	3897 mm	3168 mm	1159 mm	1200 kg	1285 kg	1365 kg
K ₂	3780 mm	2327 mm	930 mm	4978 mm	3878 mm	3139 mm	1159 mm	1950 kg	2050 kg	2130 kg
K ₃	4128 mm	2431 mm	910 mm	5885 mm	4419 mm	3881 mm	1180 mm	2250 kg	2360 kg	2480 kg
K ₄	4705 mm	2720 mm	910 mm	5730 mm 6617 mm	4321 mm 4887 mm	3767 mm 4400 mm	1180 mm 1180 mm	2550 kg	2670 kg Short Outriggers	2790 kg Standard Outriggers

B Series / Elevation Tower Options



Short-Outriggers With Ballast Weights (Freestanding)



Standart Outriggers (Freestanding)

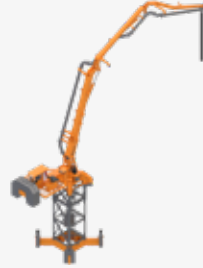

Tower Base Anchored to Deck (Anchored)



Connection Outriggers To Tower Upper Frame



Set Of Connection Outriggers (4 PCS)

Despite their lighter weights, Atabey “B-Series Spider Booms” have robust structure and long lasting operational life. The “heavy-duty slew gear” is standart on all models.

Seperate Column Unit-Upper Frame

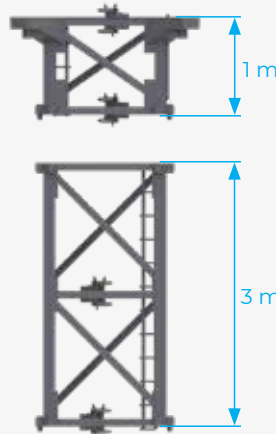

W₁: 1 m
W₂: 1.4 m

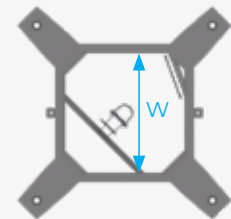

Combimed Column Unit-Upper Frame

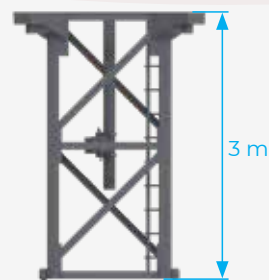

B Series / Lower Frame Options

Base Frame Unit With Standard Outriggers



Base-Frame For Slip-Form Rig Connection

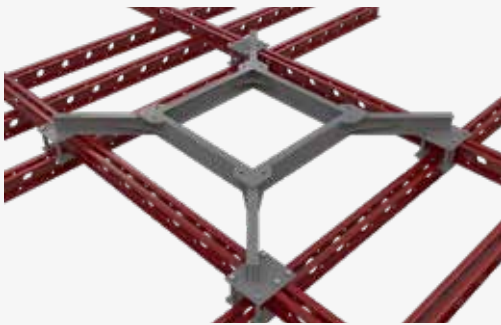

Base Frame With Short Outrigger And Ballasts

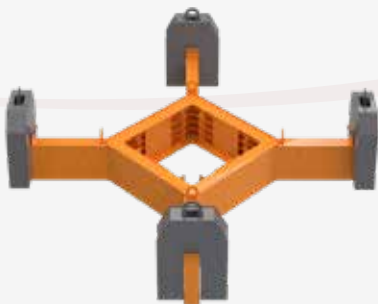

B 308, B 212, B 312, B 15, B 17, B 18 / Overall Dimensions

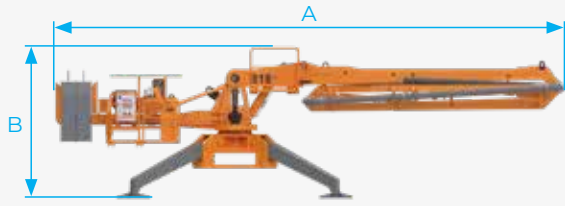

Side View

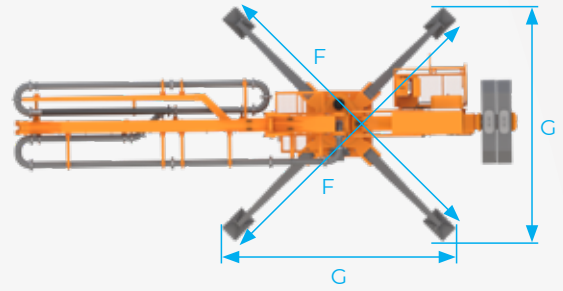

Top View

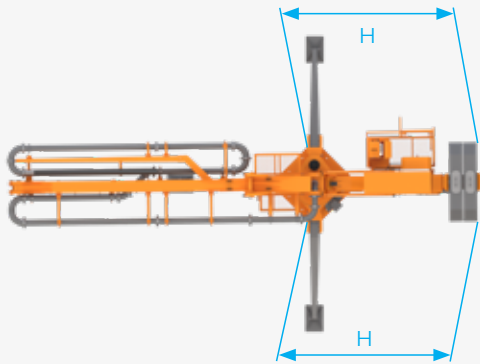

Top View

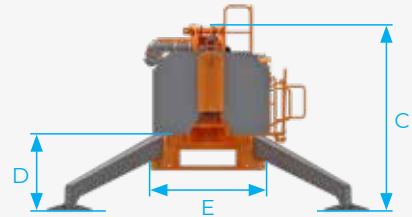

Back View

Shipping Dimensions

Alternative - 1

Assembled Unit (With Empty Ballast Boxes)

Alternative - 2

Shipping B 18 As The Boom Unit Is Detached (With Empty Ballast Boxes)

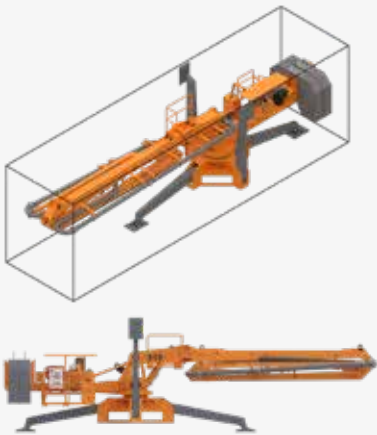

Side View

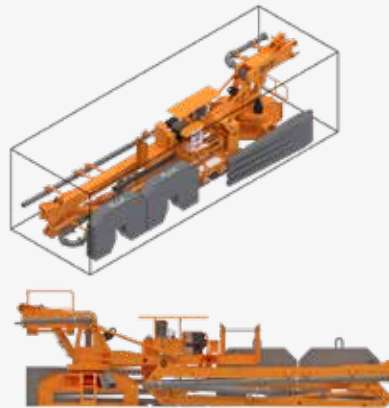

Side View

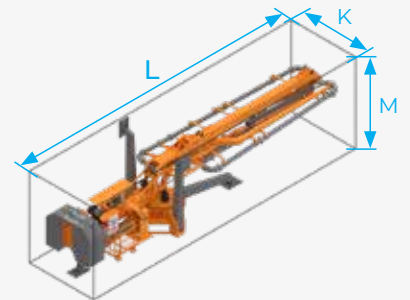

	Models					
	B 308	B 212	B 312	B 15	B 17	B 18
A	5960 mm	9774 mm	8016 mm	9365 mm	10130 mm	10760 mm
B	2400 mm	2958 mm	2958 mm	3289 mm	3428 mm	3428 mm
C	1710 mm	1878 mm	1878 mm	2359 mm	2346 mm	2346 mm
D	1050 mm	1613 mm	1613 mm	1750 mm	1500 mm	1500 mm
E	1730 mm	1455 mm	1455 mm	1684 mm	1793 mm	1793 mm
F	3310 mm	5187 mm	5187 mm	6142 mm	6590 mm	6590 mm
G	2350 mm	3859 mm	3859 mm	4616 mm	4908 mm	4908 mm
H	2360 mm	3284 mm	3273 mm	3398 mm	3499 mm	3598 mm
K	1750 mm	2000 mm	2050 mm	2000 mm	2050 mm	2050 mm
L	6000 mm	9900 mm	8100 mm	9450 mm	10250 mm	10900 mm
M	2450 mm	2800 mm	2800 mm	3220 mm	3300 mm	3300 mm

B 308, B 212, B 312, B 15, B 17, B 18 / Weights and Dimensions

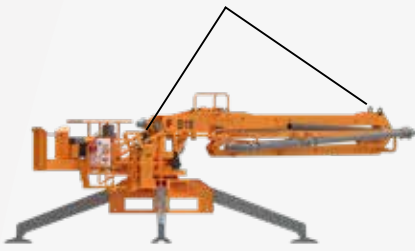

Assemble Unit

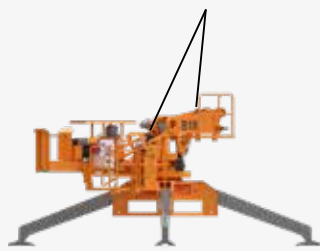

Main Frame

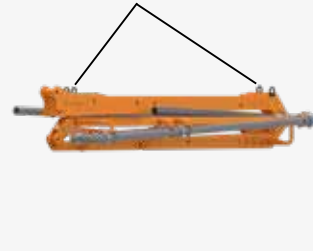

Detached Boom



Ballast

Models	Assemble Unit	Main Frame	Detached Boom	Ballast
B 308	1800 kg	BOOM: MAIN FRAME DETACHED		1 X 800kg
B 212	2210 kg	1310 kg	900 kg	1 X 1260 kg
B 312	2360 kg	1330 kg	1030 kg	2 X 750 kg
B 15	3030 kg	1800 kg	1230 kg	2 X 1000 kg
B 17	3520 kg	1980 kg	1540 kg	2 X 1300 kg
B 18	3600 kg	2060 kg	1540 kg	2 X 1300 kg

	Models					
	B 308	B 212	B 312	B 15	B 17	B 18
Distribution Diameter	16 m	24 m	24 m	30 m	35 m	36 m
Distribution Area	201 m ²	452 m ²	460 m ²	730 m ²	962 m ²	1020 m ²
Chassis Weight	Non-detacable	1310 kg	1330 kg	1800 kg	1980 kg	2060 kg
Split Boom Weight	Non-detacable	900 kg	1030 kg	1230 kg	1540 kg	1540 kg
Machine Weight (Chassis + Split Boom)	1800 kg	2210 kg	2360 kg	3030 kg	3520 kg	3600 kg
Ballast Weight	800 kg	1260 kg	1500 kg (2 X 750 kg)	2000 kg (2 X 1000 kg)	2600 kg (2 X 1300 kg)	2700 kg (2 X 1350 kg)
1. Boom Lenght	3300 mm	6475 mm	4665 mm	5640 mm	6432 mm	7360 mm
2. Boom Lenght	2500 mm	5525 mm	3718 mm	4700 mm	5503 mm	5503 mm
3. Boom Lenght	2200 mm	----	3178 mm	4700 mm	5237 mm	5237 mm
End Hose Lenght	3 m	3 m	3 m	3 m	3 m	3 m
Hydraulic Pump Engine	3 kW 3 Phase 380-400 V.	3 kW 3 Phase 380-400 V.	3 kW 3 Phase 380-400 V.	5.5 kW 3 Phase 380-400 V.	7.5 kW 3 Phase 380-400 V.	7.5 kW 3 Phase 380-400 V.
Hydraulic Tank Capacity	60 liter	60 liter	60 liter	60 liter	80 liter	80 liter
Maximum System Pressure	200 bar	200 bar	200 bar	200 bar	200 bar	200 bar
Folded Transport Lenght	5960 mm	9900 mm	8100 mm	9450 mm	10250 mm	11180 mm
Folded Transport Width	1900 mm	2000 mm	2050 mm	2000 mm	2050 mm	2050 mm
Folded Transport Height	1700 mm	2800 mm	2800 mm	3220 mm	3300 mm	3300 mm

B 21 / Technical Details

B21 Model S	
Distribution Diameter	48 m
Distribution Area	1385 m ²
Chassis Weight	3250 kg
Split Boom Weight	2050 kg
Machine Weight (Chassis + Split Boom)	5300 kg
Ballast Weight	1800 kg x 2 - 3600 kg
1. Boom Length	7987 mm
2. Boom Length	6278 mm
3. Boom Length	6284 mm
End Hose Length	3 m
Hydraulic Pump Motor	7,5 kW 3 Phase 380-400 V.
Hydraulic Tank Capacity	80 liter
Maximum System Pressure	200 bar
Folded Transport Length with Tail	12000 mm
Folded Transport Length Unassembled Tail	10850 mm
Folded Transport Width	2200 mm
Folded Transport Height	3650 mm

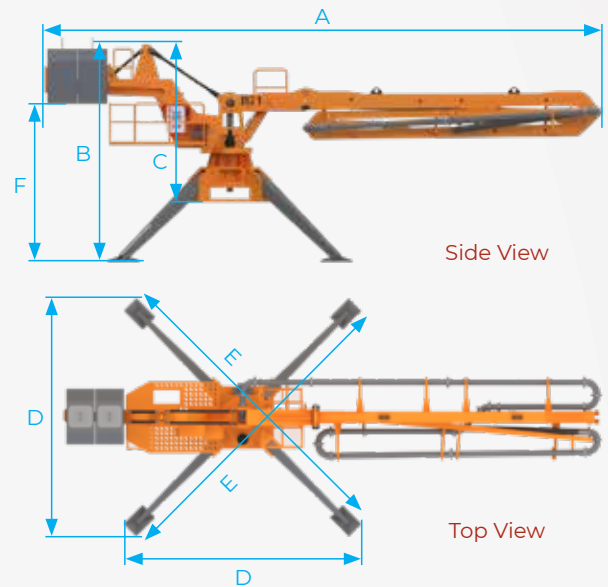

B 21 Model S	
A	11992 mm
B	4714 mm
C	3421 mm
D	5050 mm
E	6750 mm
F	3444 mm

B21 Model T	
Distribution Diameter	48 m
Distribution Area	1385 m ²
Tail Weight	500 kg
Chassis Weight	3250 kg
Split Boom Weight	2050 kg
Machine Weight (Tail + Chassis + Split Boom)	5800 kg
Ballast Weight	1800 kg
1. Boom Length	7987 mm
2. Boom Length	6278 mm
3. Boom Length	6284 mm
End Hose Length	3 m
Hydraulic Pump Motor	7,5 kW 3 Phase 380-400 V.
Hydraulic Tank Capacity	80 liter
Maximum System Pressure	200 bar
Folded Transport Length with Tail	16000 mm
Folded Transport Length Unassembled Tail	10850 mm
Folded Transport Width	2200 mm
Folded Transport Height	3650 mm

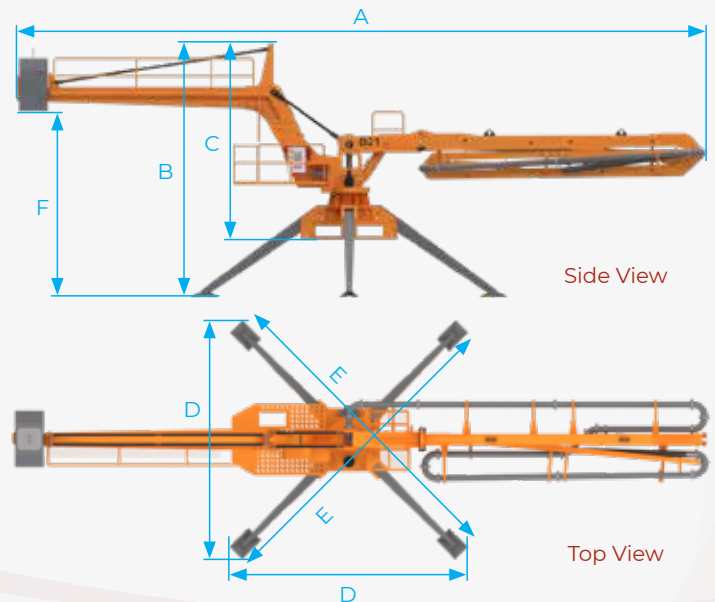

B 21 Model T	
A	15900 mm
B	5850 mm
C	4300 mm
D	5050 mm
E	6750 mm
F	4300 mm

B Series / Accessories



Hydraulic Diversion Valves
(with hand pump and/or external hydraulic line connection)



Power Packs for Diversion Valves
(electric or diesel driven)



Pipeline Scissors
(slip-form pipeline connection)



B 212, B 312 / Concrete Scatter Diagrams

B 212

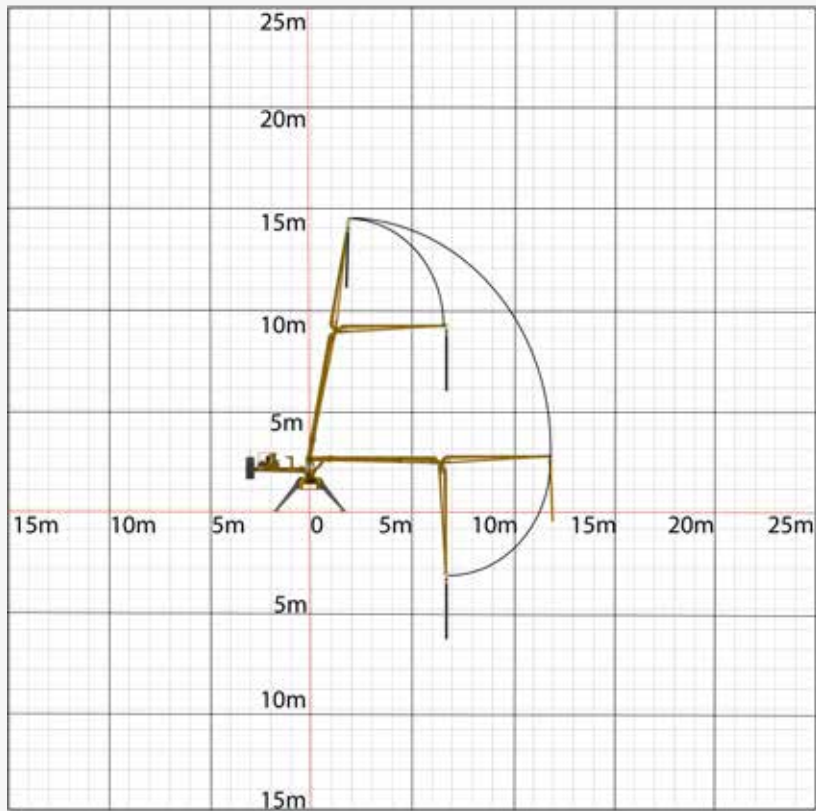

B 312

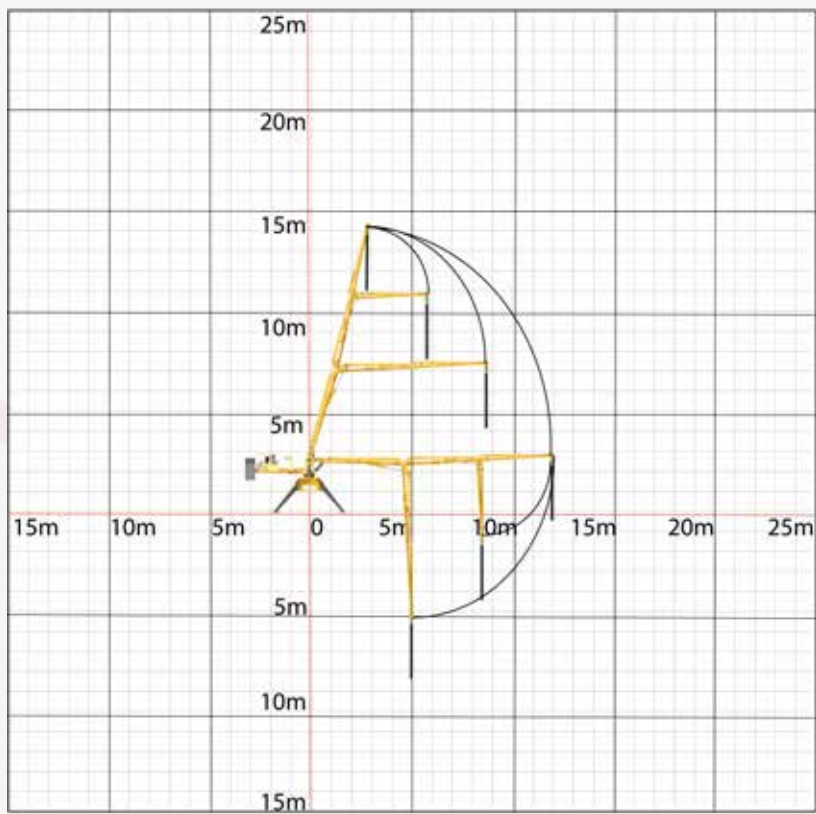

B 15, B 17 / Concrete Scatter Diagrams

B 15

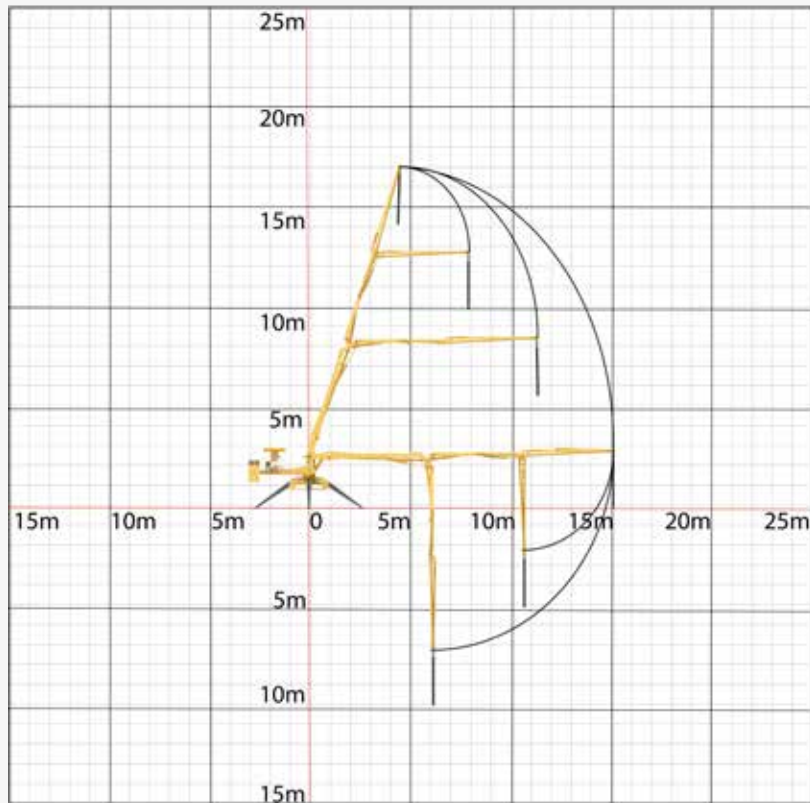

B 17

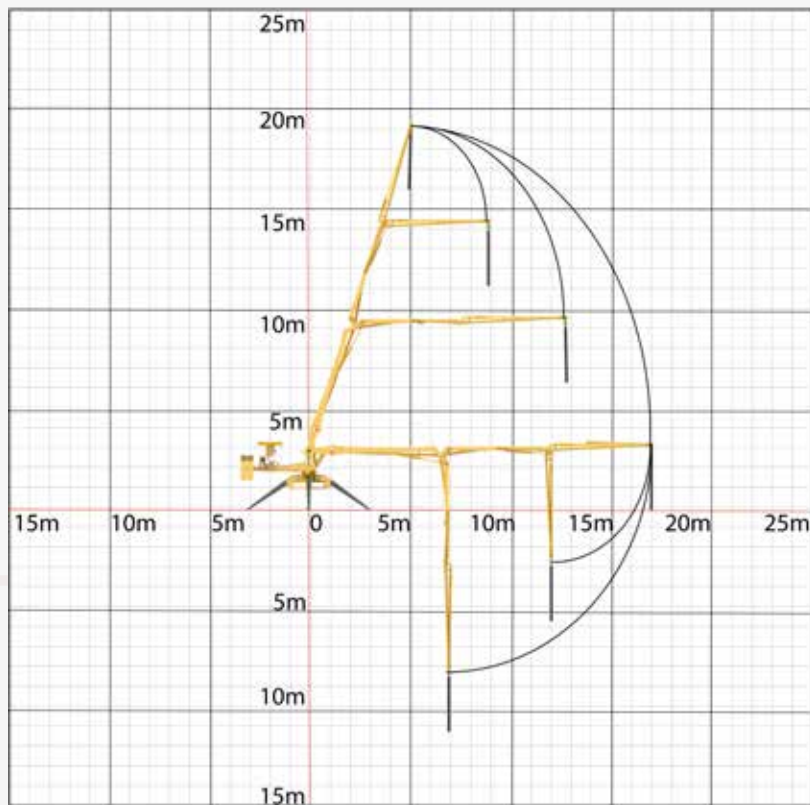



Atabey; Common language of concrete
placer's in more than 80 countries

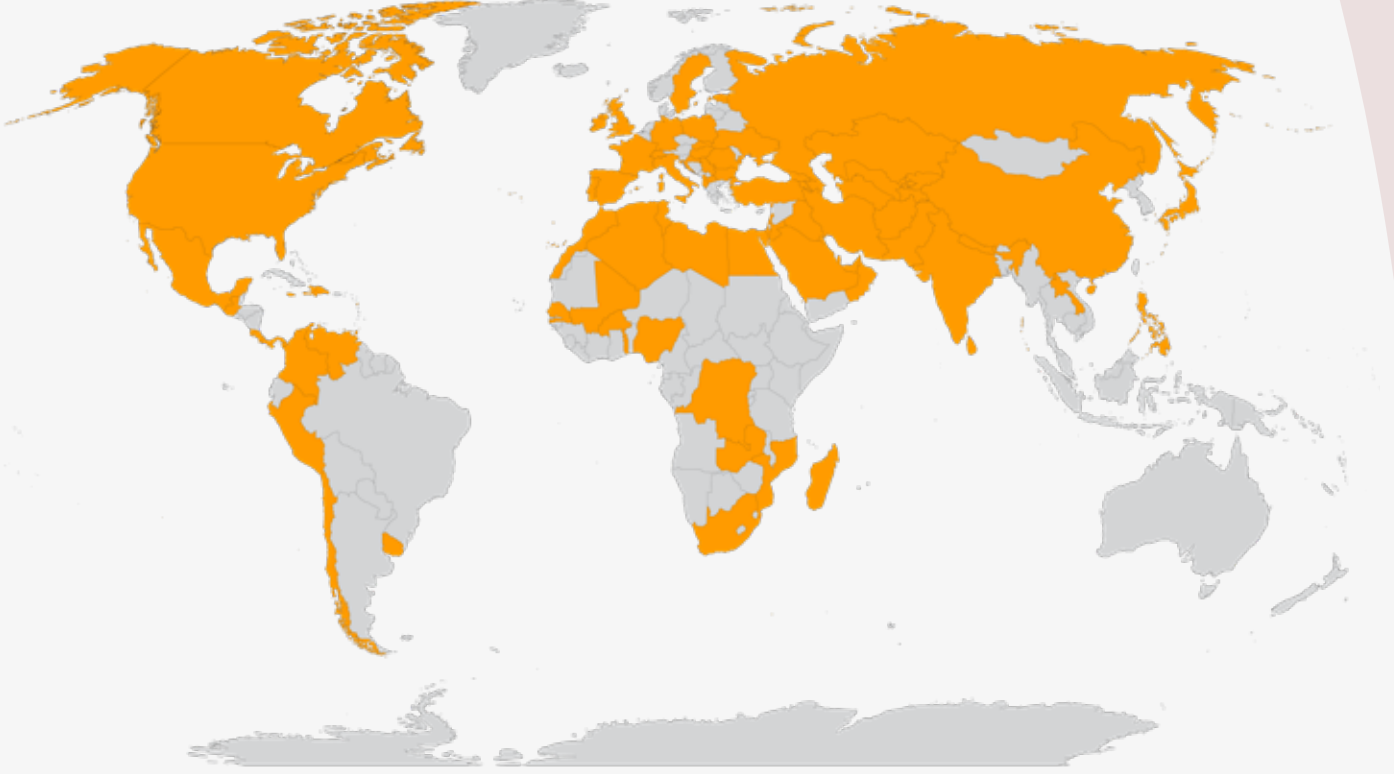

/AtabeyBetonMakinalari



/atabeyconstructionequipment



atabey construction equipment



ATABEY CONSTRUCTION EQUIPMENT

Address: Keresteciler San. Sit. 4. Cad. No: 39 Kahramankazan / Ankara - TURKEY
Phone: +90 312 441 11 33 Fax: +90 312 441 58 88
www.atabeymakina.com